



BUILD YOUR WARDROBE  
CASUAL  
CORNER.



CREATIVE  
SCARF  
TYING

BUILD YOUR WARDROBE  
CASUAL  
CORNER

ON THE COVER:  
**SQUARE  
DRAPE**

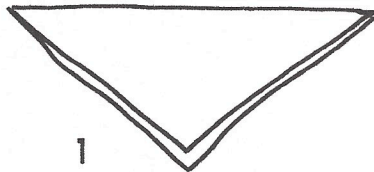

1

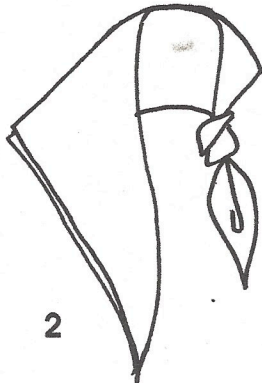

2

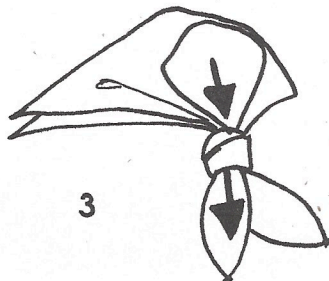

3

**SQUARE**

- Fold into a triangle and drape around neck, one side longer than the other.
- Make a large knot on short side and gather longer side; pull up through knot.
- Throw one end over shoulder and open up both ends.

**SHOULDER  
WRAP**

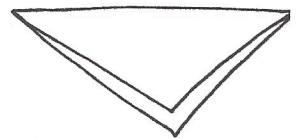

**LARGE SQUARE**

- Fold into a triangle.
- Place over one shoulder and belt at the waist.
- or
- Knot on the opposite side at the waist.

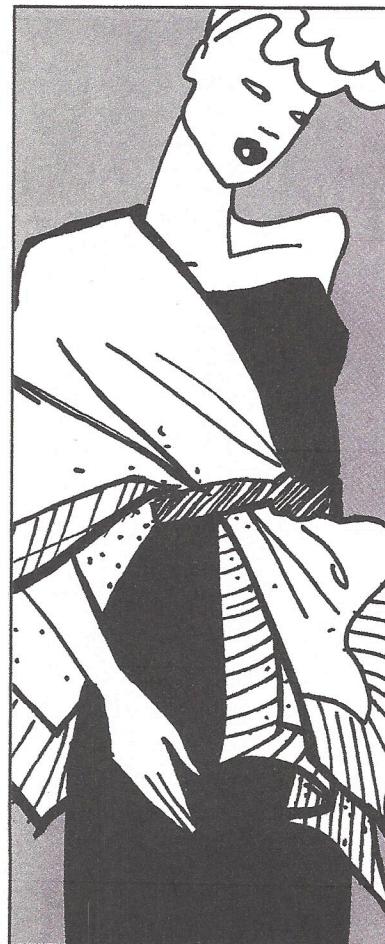



# HACKING KNOT

## OBLONG

- Fold in half lengthwise.
- Place around the neck and pull the two ends through the center fold.
- Another look: tighten the scarf to the side of the neck and form a bow.

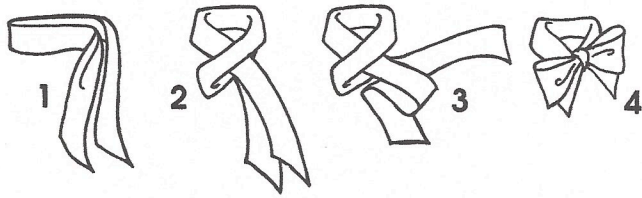

# PLEATED WRAP

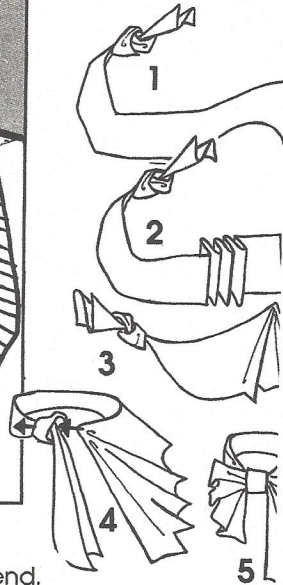

## OBLONG

- Form a simple knot close to one end.
- Accordion pleat the other end leaving enough scarf between the pleats and the knot to go around the neck.
- Release the pleats in one hand retaining them in the other.
- Place the scarf around the neck and pull pleated end into the knot in an upward direction.
- Tighten the knot and fan out the pleats.

# SLIP KNOT

## OBLONG OR BIAS

- Place around the neck with one end longer than the other.
- Tie a simple knot in the longer end.
- Place the other end into and through the knot and tighten slightly.

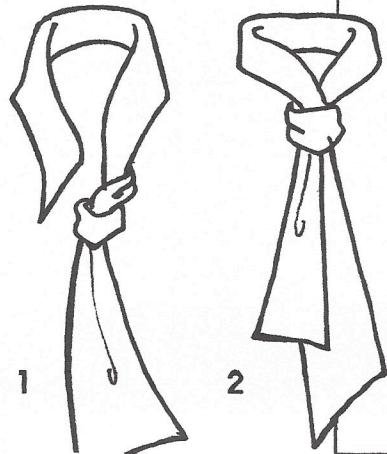

# BOW

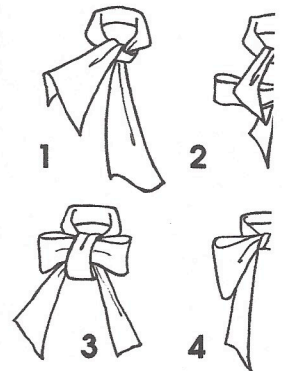

## OBLONG OR BIAS

- Flip one end over the other leaving the top end slightly long.
- Pull the lower end into a loop. Take the upper end back around the lower end.
- Push through the loop in the back forming another loop.
- Pull bow tight and adjust.





# ROSETTE

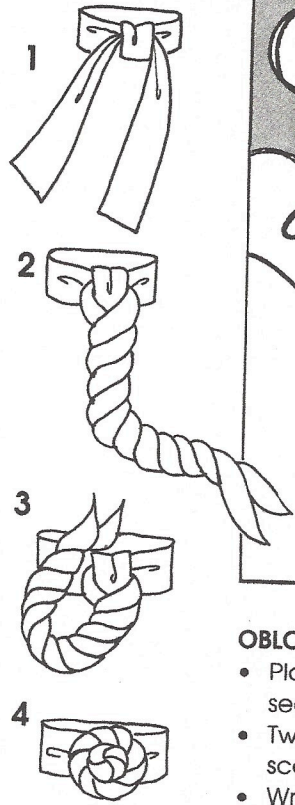

## OBLONG OR BIAS

- Place around the neck and make a secure double knot close to the neck.
- Twist both ends together until the scarf coils.
- Wrap the coil around the knot to form a rosette. Tuck ends behind.



# KNOTTED BIE



## SQUARE

- Pull the center of the wrong side and make a knot close to the end.
- Flip scarf back to the right side and into a triangle.
- Place at the neck and knot behind.

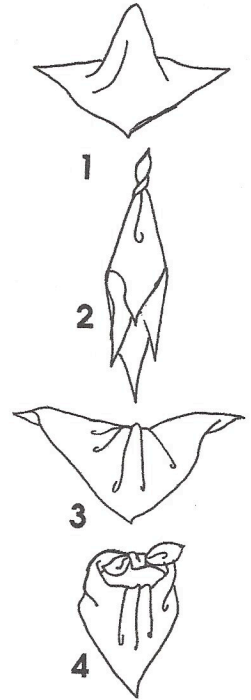

# FAUX BOW

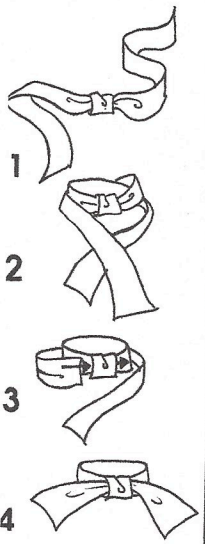

## OBLONG OR BIAS

- Make a loose knot in the center. Place knot under chin, cross ends behind the neck and bring them back to the front.
- Place the ends into the knot in opposite directions. Tighten slightly.

# EASY BOW

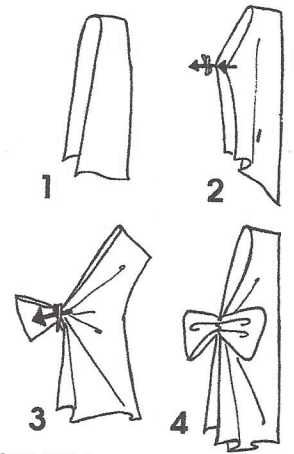

## OBLONG

- Place scarf around neck pulling two sides together at the center.
- Using a rubber band (wound tightly), pull the two sides through together.
- Pull up on the two pieces to form a bow.





# HEAD BOWS

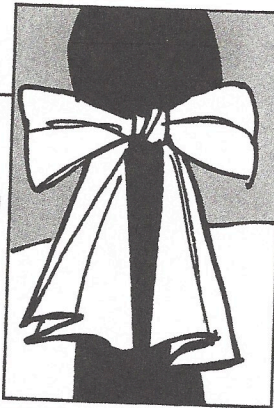
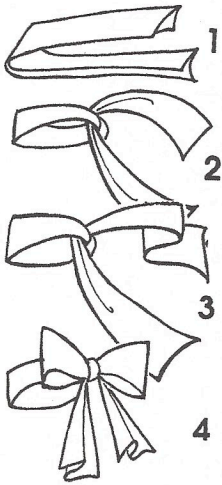

## OBLONG OR BIAS

- Fold lengthwise.
- Place around the head leaving an open top.
- Make a bow, wear to the side or back.
- or
- Secure a scarf around a ponytail and make a bow.

# BIB WRAP

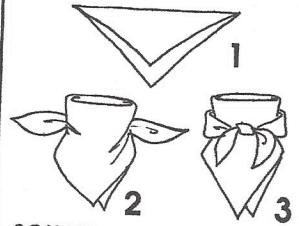

## SQUARE

- Fold into a triangle, place the pointed end in front.
- Cross ends behind neck.
- Tie in front using a square knot.

# COWL



- Take center fold of scarf and pull it over the head, tucking points into the neckline.

# SQUARE KNOT

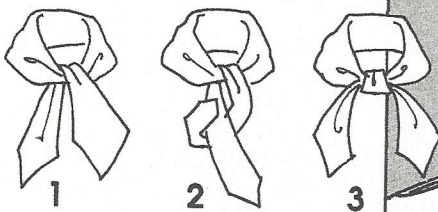

## SQUARE

- Fold into a triangle. Flip one end over the other.
- Pull the upper end around and behind the other.
- Pull through and tighten.

Knot can be worn in the front, to the side or in the



# HEAD WRAP

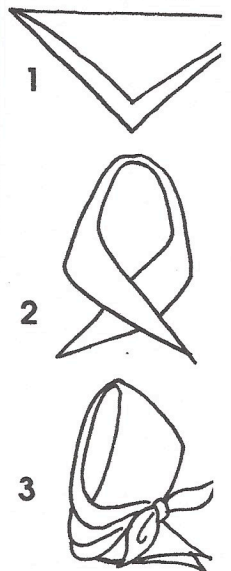

## SQUARE

- Fold into a triangle and place on head.
- Cross the ends in front, bring to the back and tie scarf over the point.



# ASCOT, FANNED OR PLEATED BOWS

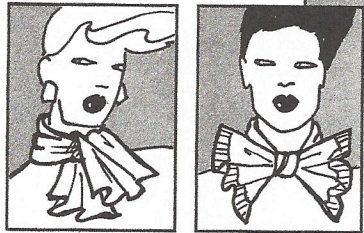

## SQUARE

- Fold into an oblong.
- Place around the neck and flip one end over the other.
- Fanned Ascot: pleat scarf with accordion folds. Wrap around neck and flip one end over the other. Fan out the pleats.
- Pleated bow: continue into a complete knot.

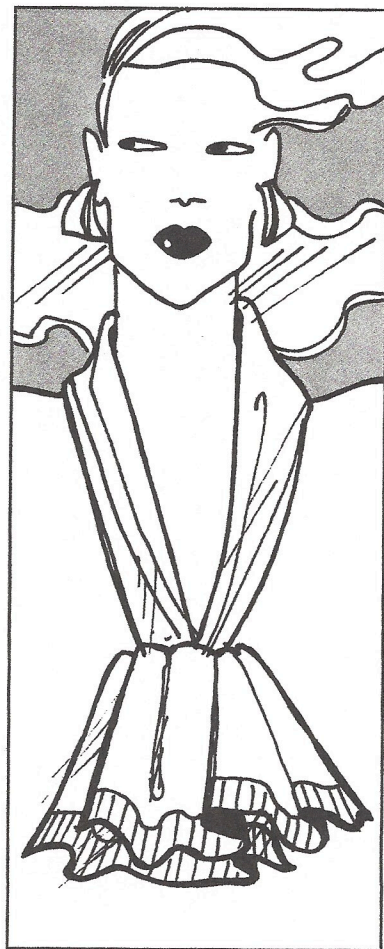
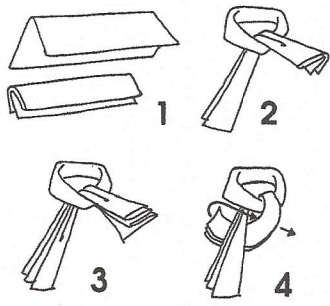

# BELL FLOWER

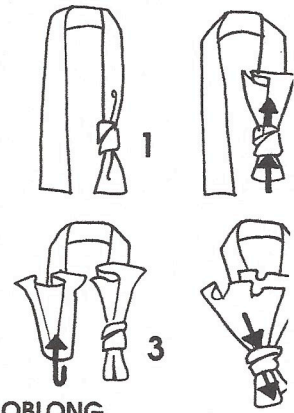

## OBLONG

- Put around neck even both sides.
- Make a knot on one side then fold scarf up at bottom and put through knot.
- On loose side, fold up scarf from bottom about 4 inches and pull folded end down through knot.
- Flip scarf over knot, hiding it.

# BUTTERFLY SHAWL

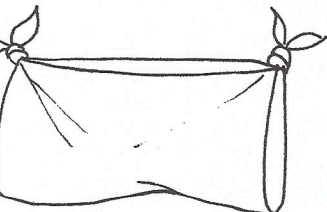
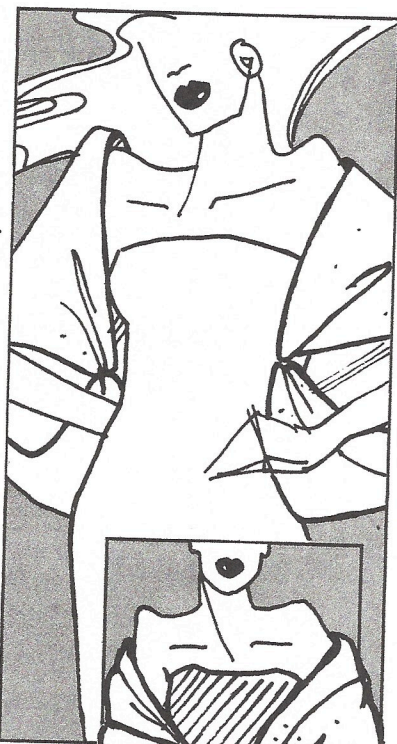

## LARGE SQUARE

- Fold in half with wrong side out. Knot two ends together on each side.
- Open to right side and place arms through openings.

# STOLE



## LARGE OBLONG

- Wear over both shoulders.

# BAY TIE



## OBLONG OR BIAS

- Put around neck and make a knot.
- Take both loose ends and twist about 6 inches.
- Curl around hand and take under knot at neck; bring down through loop in hand.

